



Pall Corporation

Differential Pressure Devices Threaded Deltadyne® Differential Pressure Indicators and Switches

Description

Operation

Deltadyne® differential pressure devices operate by sensing the differential pressure between ports upstream and downstream of the filter element. The differential pressure acts on a piston/magnet assembly that is contained in the Deltadyne device. When the differential pressure across the internal piston/magnet assembly reaches a preset value, determined by the range spring, the piston assembly moves downward sufficiently to reduce the attractive force between the magnet and indicator button or switch actuator lever. The indicator or switch spring then overcomes the reduced magnetic force to release the button or actuate the switch to signal the need for element change.

A magnet coupling isolates the pressurized fluid from the electrical or mechanical actuator. This eliminates dynamic seals and exposed cams, thus avoiding a leakage point common to other types of warning devices, particularly those which are connected to the bypass valve. Deltadyne devices respond only to differential pressures; they can withstand system pressures up to the design limit of 6000 psi (414 bar).

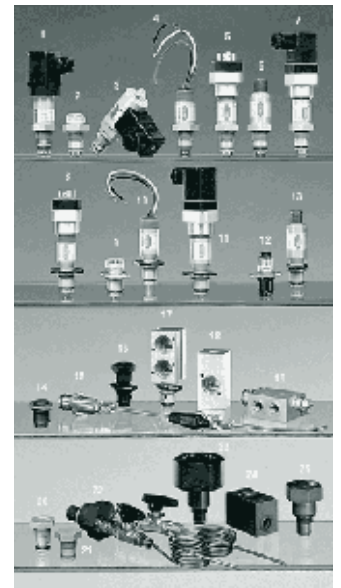

Application

Maximum Acceptable Working Pressure:

6000 psi (414 bar)

Temperature Range:

-45°F to 275°F (-43°C to 135°C)

Rated Fatigue Pressure

10^7 cycles per NFPAT.2.6.1-1974:
3000 psi (207 bar)

Seals:

Internal: Fluorocarbon
External: Nitrile or Fluorocarbon

Housing Material:

Aluminum (Stainless Steel or Other Materials Available)

Electrical Switch Ratings:

4 amp @ 110 VAC, 28 VDC (resistive)
2 amp @ 110 VAC, 28 VDC (inductive)
SPDT, automatic reset

Electrical Switch Circuit:

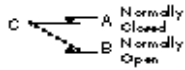

Installation:

Deltadyne switches and indicators fit Pall housings that have a threaded differential pressure port. A mounting block is available for remote installation.

Specifications

Maximum Acceptable Working Pressure:

6000 psi (414 bar)

Temperature Range:

-45°F to 275°F (-43°C to 135°C)

Rated Fatigue Pressure

10^7 cycles per NF PAT.2.6.1-1974:
3000 psi (207 bar)

Seals:

Internal: Fluorocarbon
External: Nitrile or Fluorocarbon

Housing Material:

Aluminum (Stainless Steel or Other Materials Available)

Electrical Switch Ratings:

4 amp @ 110 VAC, 28 VDC (resistive)
2 amp @ 110 VAC, 28 VDC (inductive)
SPDT, automatic reset

Electrical Switch Circuit:

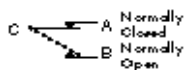

Installation:

Deltadyne switches and indicators fit Pall housings that have a threaded differential pressure port. A mounting block is available for remote installation.

Product Options

Deltadyne Switches and Indicators

Electrical Switches

Deltadyne electrical switches have an automatic reset function that allows them to be used as system warm-up monitors. High fluid viscosity associated with low temperature start-ups will cause a higher pressure drop across the filter element. Deltadyne switches will signal high differential pressure until the system reaches operating temperature. As the system warms up, the differential pressure is reduced, and the range spring returns the piston assembly to its normal position, thus restoring the magnetic force between the magnet and

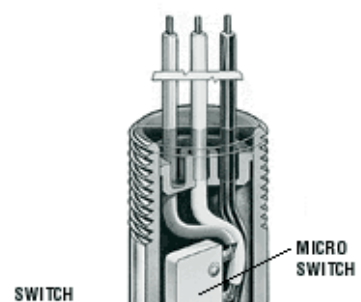

the actuator lever. The restored magnetic force is sufficient to overcome the switch spring force, allowing the single pole double throw switch (SPDT) to signal a differential pressure below the switch setting.

Single Pole Double Throw Switch:

The SPDT switch allows this device to be used in a typical green-red light circuit. When the green light signals pressure drop below the actuation pressure, there is element life remaining. The red light signals pressure drop above the preset value... either a cold start or the need for an element change. The two-light circuit also serves as a continuity check; one of the two lights should always be on.

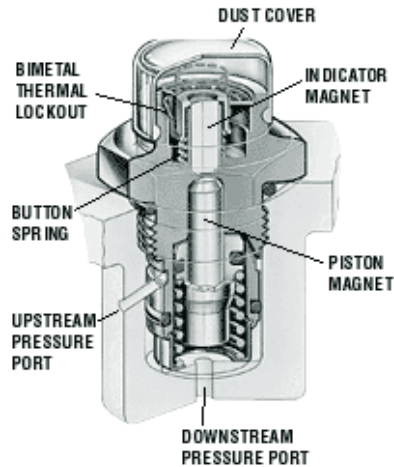
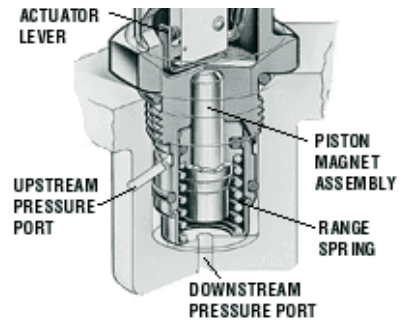

Visual Indicators

Memory:

All Deltadyne visual indicators show whether a preset differential pressure has been exceeded at any time – even after the system is shut down. When the factory-set differential pressure is exceeded, the red button pops up and stays up until it is manually reset. When the differential pressure is reduced, the range spring returns the piston assembly to its normal position; however, the gap between the magnet and the now extended indicator button is too great for magnetic force to overcome the button spring force. The button, therefore, remains in the extended position until differential pressure is reduced and the button is manually reset.

Thermal Lockout:

An optional bimetallic thermal lockout prevents actuation below 32°F and allows actuation above 80°F system temperature. Between 32°F and 80°F the thermal lockout device is in transition. Above 80°F the indicator will actuate when the element is plugged and the differential pressure exceeds the pre-set limit.

Ordering Information

RC ■ ■ ■ ■ ■

Table1 Code A Table2 Table3 Table4 Table1 Code B

Note: Choose from the options in the following tables to compile the specific Product Number.

Table 1

Code A	Code B	Description	Filter Assembly Part Number Code	"H" Dimension	Photo Reference Number
778NZ	Omit	Aluminum threaded visual indicator with memory and thermal lockout	P	0.9" (23 mm)	2
860MZ	Omit	Aluminum threaded visual indicator with memory– without thermal lockout	D	0.9" (23 mm)	2
861CZ	Omit	Aluminum threaded switch with 6" flying leads	L	1.72" (44 mm)	4
771BZ	Omit	Aluminum threaded switch with 3-pin military electric connector	S	2.25" (57 mm)	6
861CZ	YT	Aluminum threaded switch with DIN	T	3.75" (95 mm)	5

		(Hirshman) 4-pin connector		mm)	
861CZ	YM	Aluminum threaded switch with DIN (Hirshman) 4-pin connector and matching connector cap	M	3.75" (95 mm)	7
861CZ	YR110AC	Aluminum threaded switch with DIN (Hirshman) 4-pin connector, matching connector cap and 110 VAC indicator lights	R11A	4.37" (111 mm)	1
861CZ	YR220AC	Aluminum threaded switch with DIN (Hirshman) 4-pin connector, matching connector cap and 220 VAC indicator lights	R22A	4.37" (111 mm)	1
861CZ	YR24DC	Aluminum threaded switch with DIN (Hirshman) 4-pin connector, matching connector cap and 24 VDC indicator lights	R24D	4.37" (111 mm)	1
0113CZ	Omit	Aluminum threaded body with both visual and electrical switch with DIN (Hirshman) connector and a connector cap (manual reset)	V	2.7" (69 mm)	3

TABLE 2

CODE	Differential Pressure Setting	Bypass Valve Setting
084	16±3 psid (1.1±0.2 bar)	22 or 25 psid (1.5 or 1.7 bar)
090	35±5 psid (2.4±0.3 bar)	50 psid (3.5 bar)
097	100±15 psid (7.0±1.0 bar)	Non-bypass

TABLE 3

CODE	External Seal	Fluid Service
H	Nitrile	Petroleum, water oil emulsions, water-glycol, HWCF
Z	Fluorocarbon	Specified synthetics

TABLE 4

CODE	Material Option
Omit	Aluminum
SS	Stainless Steel

Threaded Filter Accessories

Part Number	Description	Photo Reference Number
1128465	Port plug kit–Buna (“B” option)	21

1128466	Port plug kit–Fluorocarbon (“B” option)	21
1326139	Dual port 1/4" SAE upstream and downstream adapter plug–Buna (“F” option)	25
1326140	Dual port 1/4" SAE upstream and downstream adapter plug–Fluorocarbon (“F” option)	25
1326193	Dual indicator adapter plug–Buna	23
1326194	Dual indicator adapter plug–Fluorocarbon	23
1129754	Gauge adapter plug kit plug–Buna	20
1313883	Gauge adapter plug kit plug–Fluorocarbon	20
1326191	Indicator remote mounting block	24
1196634	“Y” block fluid sampling kit	22

Flanged Indicators Plastic Visuals

Part Number	Pressure Setting	Description	Filter Assembly Part Number Code	"H" Dimension	Photo Reference Number
H (H) 8630DL-16	16 psid (1.1 bar)	Plastic flanged visual indicator with memory and no thermal lockout	DL	0.9" (23 mm)	12
H (H) 8630DL-35	35 psid (2.5 bar)	Plastic flanged visual indicator with memory and no thermal lockout	DL	0.9" (23 mm)	12
H (H) 8630PL-16	16 psid (1.1 bar)	Plastic flanged visual indicator with memory and thermal lockout	PL	0.9" (23 mm)	12
H (H) 8630PL-35	35 psid (2.5 bar)	Plastic flanged visual indicator with memory and thermal lockout	PL	0.9" (23 mm)	12

Aluminum Visuals

Part Number	Pressure Setting	Description	Filter Assembly Part Number Code	"H" Dimension	Photo Reference Number
H (H) 7001DM-16	16 psid (1.1 bar)	Aluminum flanged visual indicator with no thermal lockout	DM	0.9" (23 mm)	9
H (H) 7001DM-35	35 psid (2.5 bar)	Aluminum flanged visual indicator with memory and no thermal lockout	DM	0.9" (23 mm)	9
H (H) 7001PM-16	16 psid (1.1 bar)	Aluminum flanged visual indicator with memory and thermal lockout	PM	0.9" (23 mm)	9

H (H) 7001PM- 35	35 psid (2.5 bar)	Aluminum flanged visual indicator with memory and thermal lockout	PM	0.9" (23 mm)	9
------------------------	----------------------	----------------------------------------------------------------------	----	-----------------	---

Aluminum Switches

Part Number	Pressure Setting	Description	Filter Assembly Part Number Code	"H" Dimension	Photo Reference Number
H (H) 8630LL- 16	16 psid (1.1 bar)	Aluminum flanged switch with 3 wire leads and 1/2 inch NPT conduit connection	LL	1.72" (44 mm)	10
H (H) 8630LL- 35	35 psid (2.5 bar)	Aluminum flanged switch with 3 wire leads and 1/2 inch NPT conduit connection	LL	1.72" (44 mm)	10
H (H) 8630SL- 16	16 psid (1.1 bar)	Aluminum flanged switch with 3-pin military electrical connector	SL	2.25" (57 mm)	13
H (H) 8630SL- 35	35 psid (2.5 bar)	Aluminum flanged switch with 3-pin military electrical connector	SL	2.25" (57 mm)	13
H (H) 8630TL- 16	16 psid (1.1 bar)	Aluminum flanged switch with DIN (Hirshman) 4-pin connector	TL	3.75" (95 mm)	8
H (H) 8630TL- 35	35 psid (2.5 bar)	Aluminum flanged switch with DIN (Hirshman) 4-pin connector	TL	3.75" (95 mm)	8
H (H) 8630ML- 16	16 psid (1.1 bar)	Aluminum flanged switch with DIN (Hirshman) 4-pin connector and matching cap	ML	3.75" (95 mm)	11
H (H) 8630ML- 35	35 psid (2.5 bar)	Aluminum flanged switch with DIN (Hirshman) 4-pin connector and matching cap	ML	3.75" (95 mm)	11

Flanged Filter Accessories

Part Number	Description	Photo Reference Number
1303068	Port plug kit–Buna (“BL” option)	14
1303069	Port plug kit–Fluorocarbon (“BL” option)	14
1303665	Dual port 1/4" SAE upstream and downstream adapter plug–Buna (“FL” option)	19
1308337	Dual indicator adapter plug–Buna	17
1313999	Dual indicator adapter plug–Fluorocarbon	17
1305244	Gauge adapter plug kit-Buna	16
1305245	Gauge adapter plug kit-Fluorocarbon	16

1310814	Indicator remote mounting block	18
1325112	Universal fluid sampling kit	15

© 2014, Pall Corporation, Pall, and other names are trademarks of Pall Corporation.
® indicates a registered trademark in the USA.